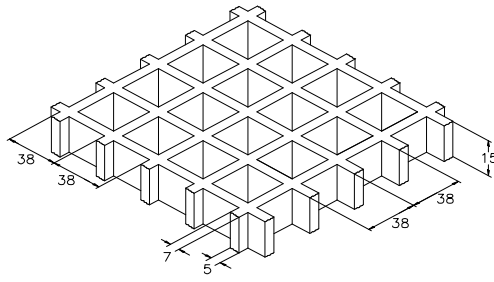

**SCH 38/15\_IFR**

06.05.2011 - Rev. 4

**MOLDED GRATINGS**

<b>Mesh</b>	mm 38 x 38	
<b>Clear span</b>	mm 31 x 31	
<b>Height</b>	mm 15	
<b>Bearing bar thickness</b>	mm 7 upper part	
	mm 5 bottom part	
<b>Color</b>	<b>Grey RAL 7004</b> <i>indicative RAL reference</i>	

<b>Raw materials</b>	<b>Polyester Resin</b>
	<b>Roving glass fiber type "E"</b>
	<b>Inorganic fillers without halogens</b>

<b>Resin type</b>	<b>Modulus of elasticity</b>	<b>Ultimate stress</b>
<b>IFR</b>	15000 MPa	325 MPa

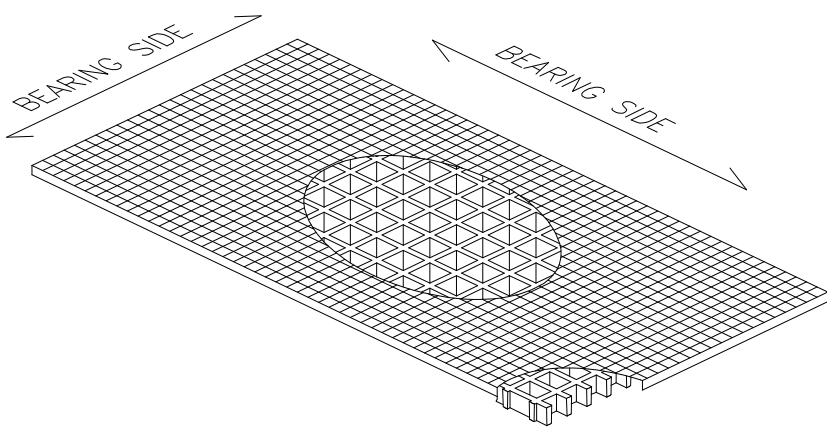
<b>Standard panels</b>	
mm 1220 x 3660	
<b>Weight kg/m<sup>2</sup> 5</b>	
<b>tolerance</b>	± mm 5 panel dimensions ± mm 2 height

<b>Surface</b>	S	<b>Smooth</b>	<b>Antiskid level R10 V10 norm DIN 51130</b>
	M	<b>Meniscus</b>	<b>Antiskid level R13 V10 norm DIN 51130</b>
	A	<b>Quartz</b>	<b>Antiskid level R13 V10 norm DIN 51130</b>

<b>Reaction to fire</b>	<b>Fire retardant</b>	<b>Spread ≤ 25 norm ASTM E84-98</b>
		<b>Level B<sub>fl</sub>-S1 norm EN 13501-1</b>

<b>Ageing resistance</b>	<b>Ageing test made with UV lamp according to ASTM G154-06 and passed with 5 points on the gray range and without evident defects</b> (test made with 1500 hours of exposure to 4 hours alternate cycles at a UV temperature of 60°C and 4 hours at a condensed temperature of 50°C irradiated by UVB 313 nm lamp, radiance 0,71 W/m <sup>2</sup> )
	<b>After the exposure to heat, cold and humidity cycles according to UNI EN ISO 9142/04 norm (n° 21 cycles type D3) there is no evidence of defects</b>

## LOADS

### MAXIMUM SUGGESTED LOADS

Type of support	<b>On the line of the two ends of the panel</b>
Limits determined by	<b>Deflection</b> (load sagging)
the <b>maximum deflection admitted</b> , is 1/200 of the distance between the supports	
According to the standard DIN 24537-3 deviation due to the load may be no more than 1/200 of the land width and the difference in height between neighbouring joints between loaded and unloaded floor coverings may be no more than 4 mm.	

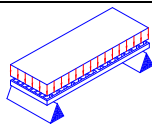
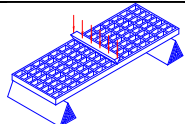
<b>DISTRIBUTED LOAD</b>			<b>CONCENTRATED LOAD</b>		
					
Distance between supports	Load with deflection equal to 1/200	Load with deflection equal to 1/100	Distance between supports	Load with deflection equal to 1/200	Load with deflection equal to 1/100
[cm]	[kg/m <sup>2</sup> ]		[cm]	[kg/m]	
30	950	1900	30	150	350
50	200	400	50	50	100
70	50	150	70	0	50
90	0	50	90	0	0

All lighter loads are admitted

Limits determined by	<b>Admitted stresses</b> (stress determined by the load)
the <b>maximum admitted stress</b> is 1/5 of the ultimate stress (safety factor is equal to 0.20 – the ultimate stress is 5 times the specified load)	

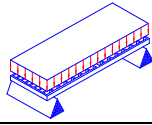
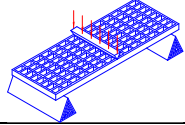
<b>DISTRIBUTED LOAD</b>		<b>CONCENTRATED LOAD</b>		
				
Distance between supports	Maximum admitted load		Distance between supports	Maximum admitted load
[cm]	[kg/m <sup>2</sup> ]		[cm]	[kg/m]
30	3250		30	450
50	1150		50	250
70	600		70	200
90	350		90	150

All lighter loads are admitted

- The above characteristics are meant as reference values for standard material in ambient working temperature. Even if they are not to be considered as guaranteed characteristics they are based on our experience and are supplied in good faith.
- According to the standard DIN 24537-3 the conversion safety factor should be 0.75 for internal environmental exposure conditions, 0.65 for external exposure conditions, and 0.50 for aggressive exposure conditions.
- No matter which are the exposure conditions, chemical resistance must be always verified by contacting M.M. technical department.
- In case of heavy duty load compressive strength must be verified.